

WasteShredder 600

WasteShredder 600 captures and shreds waste from inline and offline processes. It reduces bulky materials into smaller pieces that can be easily transported in a pneumatic conveying system for easy collection in a Lundberg Tech All-in-One Unit or a Central System.

The WasteShredder is ideal for shredding carton, empty boxes, logistic waste, single bags, empty food trays and other flexible packaging. It can be placed centrally in your production to ensure that waste is quickly shredded and transported away from the production area.

The WasteShredder can be equipped with different inlets, depending on application.

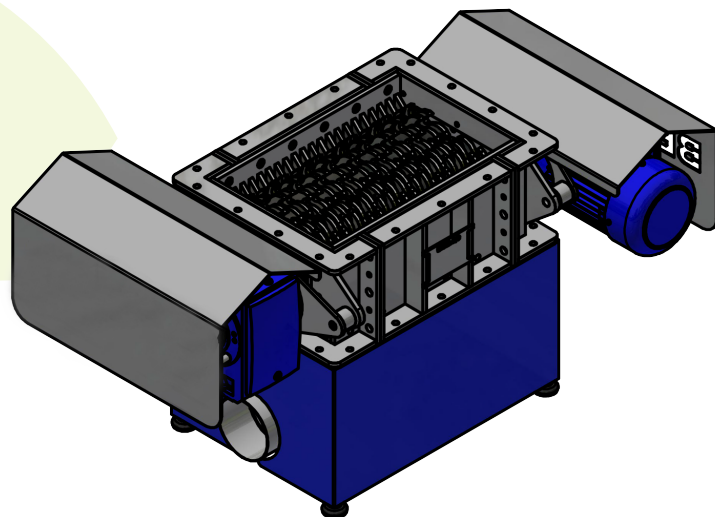

Technical Data:

Inlet size	600 x 370
Rotor	2
Rotor speed	50 RPM
Number of rotor knives	22 x 8
Pipe connection	Dia. 160 transfer
Size (LxWxH)	1375 x 1005 x 700 mm
Motor kW	2 x 3 kW
Weight	720 kg
Power	3x400V, 50 Hz
Nominal current	11 A
Fuse	16 A
Sound	<80 dB (A)
Colour	RAL5010

